

Presentation of the 5-bus test system

Thierry Van Cutsem

`thierry.h.van.cutsem@gmail.com`
`https://thierrylvancutsem.github.io/home/`

December 2024

System overview

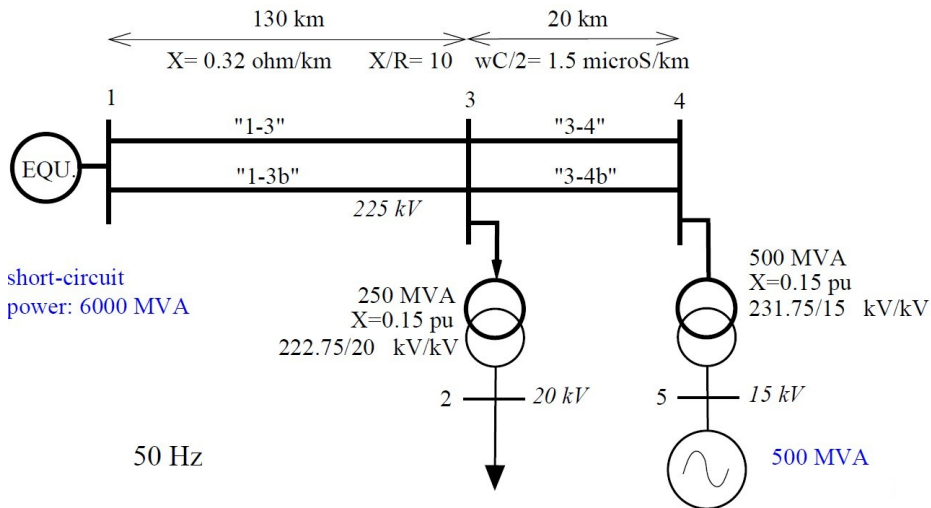

Thévenin equivalent

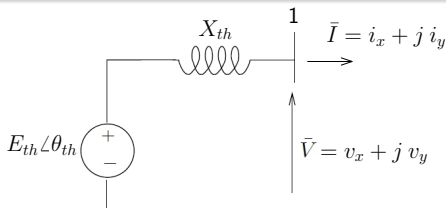

$$X_{th} = \frac{1}{\frac{S_{sc}}{S_{base}}} = \frac{100}{6000} = 0.0167 \text{ pu}$$

S_{sc} : short-circuit power¹

S_{base} : base power of network = 100 MVA

$$E_{th} \angle \theta_{th} = \bar{V} + j X_{th} \bar{I}$$

$$\iff E_{th} \cos \theta_{th} + j E_{th} \sin \theta_{th} = (v_x + j v_y) + j X_{th} (i_x + j i_y)$$

Algebraic-only model:

$$E_{th} \cos \theta_{th} - v_x + X_{th} i_y = 0$$

$$E_{th} \sin \theta_{th} - v_y - X_{th} i_x = 0$$

¹more precisely: contribution of Thévenin equivalent to short-circuit power at bus 1

Synchronous machine

Round-rotor machine

typical of thermal power plants

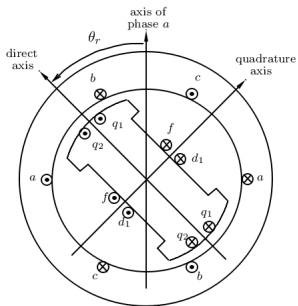

f : field (or excitation) winding

d_1 : direct-axis damper winding

q_1, q_2 : quadrature-axis damper windings

After applying Park transformation:

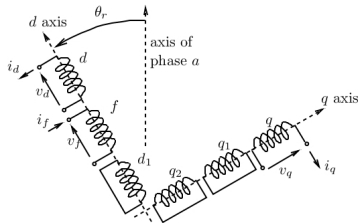

3-phase stator replaced by d, q windings.

Inductance matrices:

$$\mathbf{L}_d = \begin{bmatrix} L_\ell + M_d & M_d & M_d \\ M_d & L_{\ell f} + M_d & M_d \\ M_d & M_d & L_{\ell d1} + M_d \end{bmatrix}$$

$$\mathbf{L}_q = \begin{bmatrix} L_\ell + M_q & M_q & M_q \\ M_q & L_{\ell q1} + M_q & M_q \\ M_q & M_q & L_{\ell q2} + M_q \end{bmatrix}$$

- independent of rotor position
- d and q axes decoupled
- in per unit, using the proper base 4/15

Magnetic saturation of material

Open-circuit characteristic:

- machine operating at no load, rotating at nominal angular speed
- terminal voltage E_q measured for various values of the field current i_f

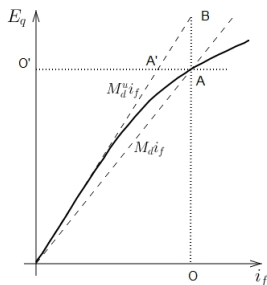

$$\text{Saturation factor : } k = \frac{OA}{OB} = \frac{O'A'}{O'A} < 1$$

$$\text{A standard model : } k = \frac{1}{1 + m(E_q)^n} \quad m, n > 0$$

Electrical part of model in (d, q) reference frame with phasor approximation

$$\psi_d = L_\ell i_d + \psi_{ad}$$

$$\psi_q = L_\ell i_q + \psi_{aq}$$

$$\psi_f = L_{\ell f} i_f + \psi_{ad}$$

$$\psi_{q1} = L_{\ell q1} i_{q1} + \psi_{aq}$$

$$\psi_{d1} = L_{\ell d1} i_{d1} + \psi_{ad}$$

$$\psi_{q2} = L_{\ell q2} i_{q2} + \psi_{aq}$$

$$\psi_{ad} = M_d (i_d + i_f + i_{d1})$$

$$\psi_{aq} = M_q (i_q + i_{q1} + i_{q2})$$

$$M_d = \frac{M_d^u}{1 + m \left(\sqrt{\psi_{ad}^2 + \psi_{aq}^2} \right)^n}$$

$$M_q = \frac{M_q^u}{1 + m \left(\sqrt{\psi_{ad}^2 + \psi_{aq}^2} \right)^n}$$

$$\frac{1}{\omega_N} \frac{d}{dt} \psi_f = v_f - R_f i_f$$

$$\frac{1}{\omega_N} \frac{d}{dt} \psi_{q1} = -R_{q1} i_{q1}$$

$$\frac{1}{\omega_N} \frac{d}{dt} \psi_{d1} = -R_{d1} i_{d1}$$

$$\frac{1}{\omega_N} \frac{d}{dt} \psi_{q2} = -R_{q2} i_{q2}$$

$$v_d = -R_a i_d - \omega \psi_q - \cancel{\frac{d\psi_d}{dt}}$$

$$v_q = -R_a i_q + \omega \psi_d - \cancel{\frac{d\psi_q}{dt}}$$

- M_d^u (resp. M_q^u) non-saturated value of M_d (resp. M_q)
- ψ_{ad} (resp. ψ_{aq}): air-gap flux in d (resp. q) axis
- all variables in per unit, except time t
- $\omega_N = 2\pi f_N$ f_N : nominal frequency

Connecting the model to the (x, y) reference frame

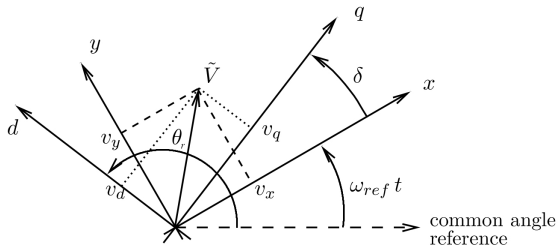

δ : "rotor angle"

Motion equation

$$\frac{1}{\omega_N} \frac{d}{dt} \delta = \omega - \frac{\omega_{ref}}{\omega_N} \quad \omega: \text{rotor speed in per unit}$$

$$2H \frac{d}{dt} \omega = T_m - T_e = T_m - (\psi_d i_q - \psi_q i_d)$$

T_m : mechanic torque given by turbine

T_e : electromagnetic torque opposed by machine

$$H = \frac{\frac{1}{2} I \left(\frac{\omega_N}{p} \right)^2}{S_N} \quad \text{inertia constant (in s)}$$

I : moment of inertia of *all* rotating masses p : number of pair of poles

S_N : nominal apparent power of machine (in MVA)

Data

$$S_N = 500 \text{ MVA}$$

$$U_N = 15 \text{ kV}$$

stator (or armature): resistance $R_a = 0$. leakage react. $X_\ell = 0.15 \text{ pu}$

synchronous reactance*: d-axis $X_d = 2.20 \text{ pu}$ q-axis $X_q = 2.00 \text{ pu}$

transient reactance*: d-axis $X'_d = 0.30 \text{ pu}$ q-axis $X'_q = 0.40 \text{ pu}$

subtransient reactance*: d-axis $X''_d = 0.20 \text{ pu}$ q-axis $X''_q = 0.20 \text{ pu}$

open-circuit transient

time constant*: d-axis $T'_{do} = 7.00 \text{ s}$ q-axis $T'_{qo} = 1.50 \text{ s}$

open-circuit subtransient

time constant*: d-axis $T''_{do} = 0.05 \text{ s}$ q-axis $T''_{qo} = 0.05 \text{ s}$

saturation $m = 0.10$ $n = 6.0257$

inertia: $H = 4 \text{ s}$

* used at initialization to obtain $L_{\ell f}, L_{\ell d1}, M_d^u, R_f, R_{d1}, L_{\ell q1}, L_{\ell q2}, M_q^u, R_{q1}, R_{q2}$

Speed governor and steam turbine

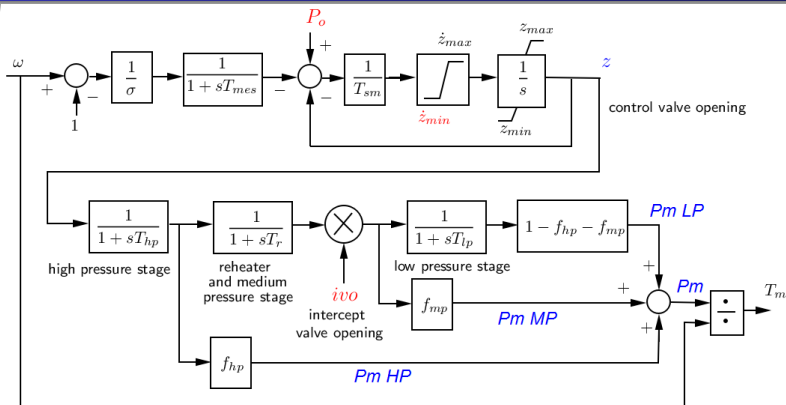

Turbine nominal power $P_{nom} = 460$ MW. All variables in pu on the P_{nom} base.

$$\sigma = 0.04 \quad T_{mes} = 0.1 \text{ s} \quad T_{sm} = 0.4 \text{ s}$$

$$\dot{z}_{min} = -0.05 \text{ pu/s} \quad \dot{z}_{max} = 0.05 \text{ pu/s} \quad z_{min} = 0. \quad z_{max} = 1. \text{ pu}$$

$$T_{hp} = 0.3 \text{ s} \quad f_{hp} = 0.4 \quad T_r = 5.0 \text{ s} \quad f_{mp} = 0.3 \quad T_{lp} = 0.3 \text{ s} \quad ivo = 1$$

Automatic voltage regulator, excitation system and overexcitation limiter

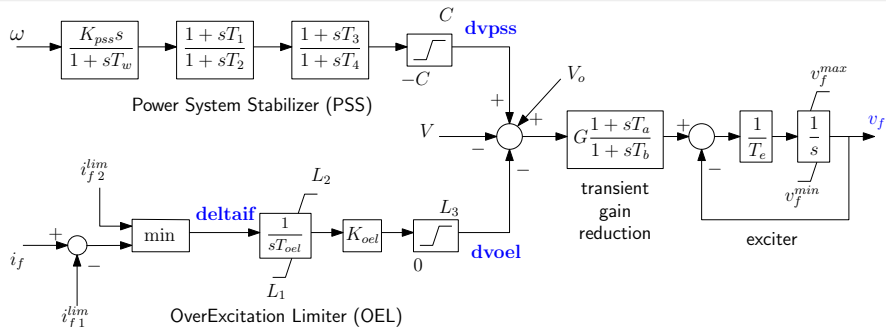

All variables on the base (voltage and current) of the excitation system.

$$G = 70. \quad T_a = T_b = 1 \text{ s} \quad T_e = 0.4 \text{ s} \quad v_f^{\min} = 0. \quad v_f^{\max} = 5 \text{ pu}$$

$$K_{pss} = 50 \quad T_w = 5 \text{ s} \quad T_1 = T_3 = 0.323 \text{ s} \quad T_2 = T_4 = 0.0138 \text{ s} \quad C = 0.06 \text{ pu}$$

$$i_{f1}^{\text{lim}} = 2.90 \text{ pu} \quad i_{f2}^{\text{lim}} = 1.00 \text{ pu} \quad T_{oel} = 12 \text{ s} \quad K_{oel} = 2.0$$

$$L_1 = -1.1 \quad L_2 = 0.1 \quad L_3 = 0.2 \text{ pu}$$

Load

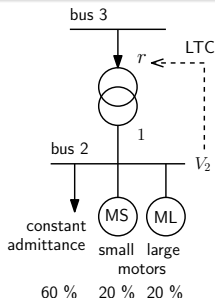

Induction motor model :

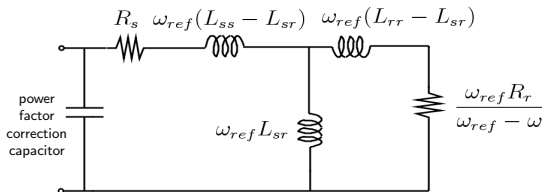

$$\text{Dynamics of rotor speed : } 2H \frac{d\omega}{dt} = T_e - T_{mo}(A\omega^2 + B)$$

Constant admittance load: $P = GV^2 = P_o(V/V_o)^2$ $Q = -BV^2 = Q_o(V/V_o)^2$

MS: equivalent motor representing a population of "small motors"*:

$$R_s = 0.031 \quad L_{ss} = 3.30 \quad L_{sr} = 3.20 \quad L_{rr} = 3.38 \quad R_r = 0.018 \text{ pu}$$

$$H = 0.7 \text{ s} \quad A = 0.5 \quad B = 0.5$$

ML: equivalent motor representing a population of "large motors"*:

$$R_s = 0.013 \quad L_{ss} = 3.867 \quad L_{sr} = 3.80 \quad L_{rr} = 3.97 \quad R_r = 0.009 \text{ pu}$$

$$H = 1.5 \text{ s} \quad A = 0.5 \quad B = 0.5$$

* values in pu on the motor MVA base

Load Tap Changer (LTC)

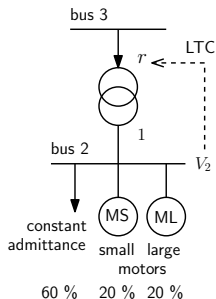

Range of variation of ratio r :

- minimum: 0.81
- maximum: 1.10
- number of tap positions: 30

Voltage control logic:

if $V_2 < V_2^o - \epsilon$ decrease r by one position

if $V_2 > V_2^o + \epsilon$ increase r by one position

else leave r unchanged

$$V_2^o = 1.00 \text{ pu} \quad \epsilon = 0.01 \text{ pu}$$

Delays:

- before first tap change: 25 s
- between successive tap changes: 10 s

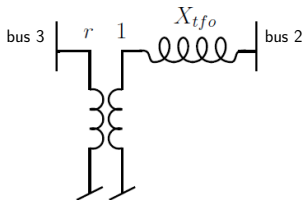

Operating point # 1

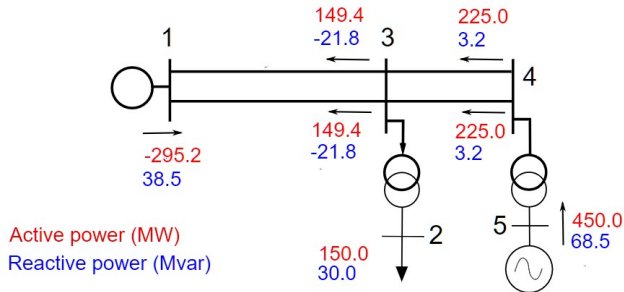
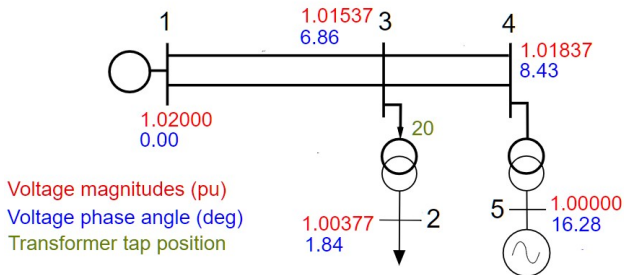

Operating point # 2

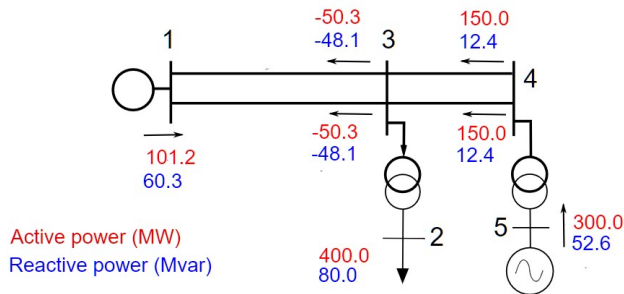
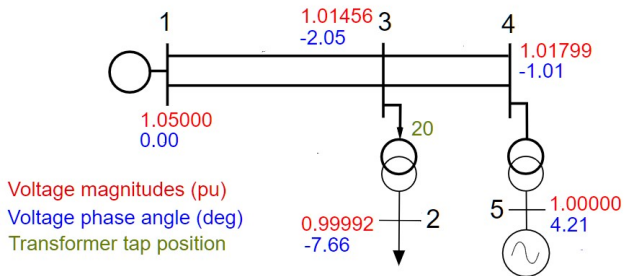

Operating point # 3

